

F | S

FABRICS-STORE.COM

Our linen is nothing short of addicting

Classic Bedding Collection

Part II

*Cool in the summer and warm in the winter,
linen sheets are your best night's sleep year
round. Lasting several years if not decades,
becoming softer and softer with each wash.*

Sizes: Twin, Full, Queen, King & California King



Classic Fitted & Flat Sheets

As an indulgent and sensible investment, linen sheets are attractive, naturally comfortable and durable. Here we present everything you will need to know for the cutting and fine sewing of your own luxurious set.

Fully illustrated instructions for the advanced beginner, requiring only a straight-stitch sewing machine.

PICTURED: LAURA LOUNGING WITH LINEN BEDDING. BLEACHED WHITE SHEETS, REVERSIBLE DUVET COVER IN ASPHALT AND NINE IRON



CLASSIC LINEN BED SHEETS

A set of sheets crafted in 100 percent linen is as luxuriously attractive as it is comfortable and inviting for a cozy night's sleep. Becoming softer with each washing and lasting several years, it is both an indulgent and sensible investment.

Pattern directions and yardage guides are specified for all bed sizes with cleverly hidden horizontal seaming. Only one seam is needed for the Flat Sheet. The Fitted Sheet has one seam hidden under the pillows, and the other seam at the foot of the bed. You will find these seams to be virtually undetectable using our instructions for a clean-finished open seam.

Fully illustrated instructions are written with the advanced beginner in mind, requiring only the use of a straight stitch sewing machine. Included techniques are French seams, open flat felled seams, and elastic casings to allow for easily replacing worn elastic corners.



Bonus feature! We have also included machine-embroidery design files of a stylish “bee” to add an optional designer touch. Also included is a printable template to embroider the design by hand. (See page 21)

Flat Sheet

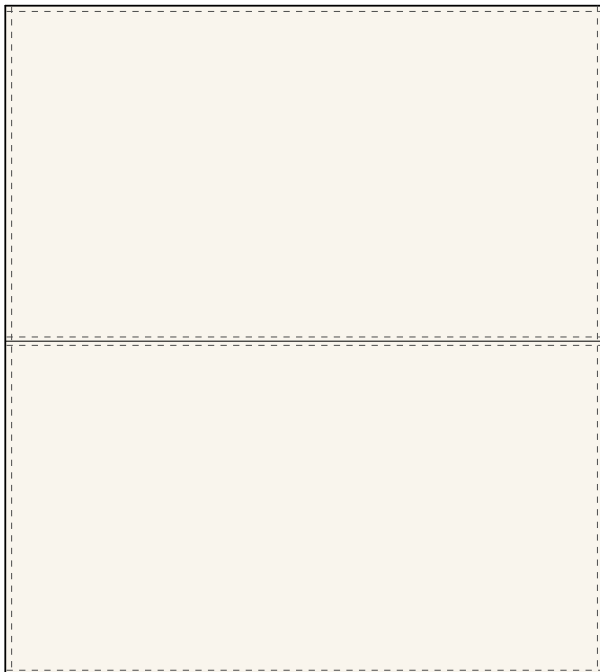

Fitted Sheet

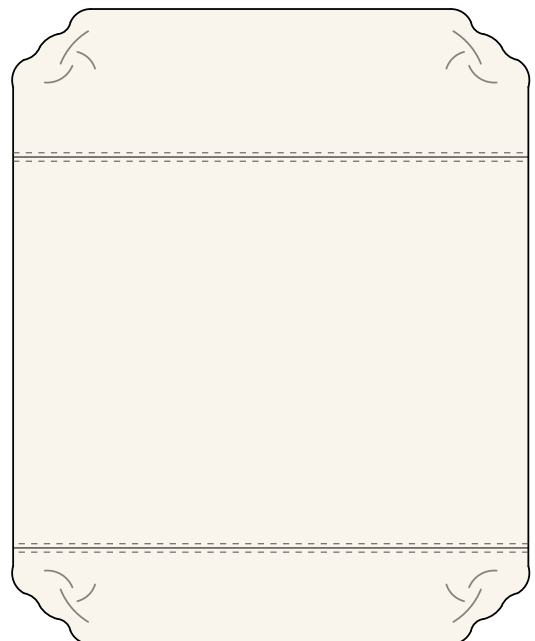

FABRIC & SUPPLIES NEEDED

Fabric: Recommended for our medium and lightweight linen. Please refer to the bed size charts for the amount of fabric you will need. Click to browse our entire collection of our popular [5.3 oz Middle Weight IL019](#), our higher thread count [5.3 oz Middle Weight IC64](#) and for a more airy experience, our [3.5 oz IL020 Handkerchief Linen](#).

Elastic: 2 yards 1/2"-5/8" wide elastic for corners of fitted sheet.

Fusible Interfacing: About 1/8 yard medium weight fusing- or enough scraps to fuse 8 small squares 1.5" x 1.5"

Thread: 2 spools all purpose thread, matching the color of your linen.

Scissors: Sharp scissors for cutting fabric.

Straight pins: Dressmakers straight pins, preferably with glass ball heads (plastic ball heads can melt!)

For markings: Fabric marking pencils, chalk or air/water erasable markers, or tracing paper... whatever your preferred method is. Be sure to test your method on a scrap of spare fabric before marking your actual project fabric.

Sewing machine: You will only need a straight-stitch machine for this pattern- there is no need for a serger or overlock machine since all seams are clean finished. A standard Universal needle in size 80/12 is recommended.

Iron: A steam iron with a non-stick surface is recommended, along with a press cloth.

Cardboard grid cutting mat (optional): These economical cardboard mats are generally sized 36x60 inches each and are excellent for cutting your panels true on-grain with accurate squared corners. Purchasing two or three to join together and put on top of your bed makes a nice cutting area for sizeable projects when you do not have a large cutting table.

SIZING AND YARDAGE CHARTS

Yardage needed of unwashed 57" Linen			
Shrinkage up to 10% is already calculated and rounded up to the nearest yard. You will wash linen before cutting.			
Bed Size	Flat Sheet Size	Fitted Sheet Size	Total Yardage Needed
Twin	72"W x 102"L	40"W x 76"L x 18"D	11 yards incl. 1 Pillowcase
Full	81"W x 102"L	55"W x 76"L x 18"D	12 yards incl. 1 Pillowcase
Queen	100"W x 109.5"L	60"W x 80"L x 18"D	14 yards incl. 1 Pillowcase
King	118"W x 109.5"L	78"W x 80"L x 18"D	17 yards incl. 1 Pillowcase
Cali King	118"W x 109.5"L	72"W x 84"L x 18"D	17 yards incl. 1 Pillowcase

Pre-washing:

You will want to prewash and dry your linen fabric in the same manner you would your finished items. This will soften your fabric, and eliminate further shrinkage in your final sewn sheets. On average, the fabric will shrink about 10%.

There may be lint accumulation depending on your detergent and water type, but this will decrease with each washing.

Secure the raw edges with a zig-zag or serger before washing to avoid fraying. For very long cuts of fabric, it may be less bulky in the wash if you fold the fabric in half and secure the two layers together with a large basting machine stitch (about 4mm)

Remove fabric from dryer while it is still slightly moist. Press any deep creases or wrinkles using your iron's steam setting with high heat, using a protective press cloth if needed to avoid scorching. Carefully trim off the selvage edges. *Tip* You may want save the selvage edges to use creatively on other projects.

If you plan on only dry cleaning your sheets, likewise you will want to dry clean the fabric before cutting and sewing.

PATTERNS & CUTTING GUIDES

TWIN FITTED & FLAT SHEET

PATTERN DIMENSIONS

Pattern includes all seam allowances. The indicated dimensions are for the CUT lines.

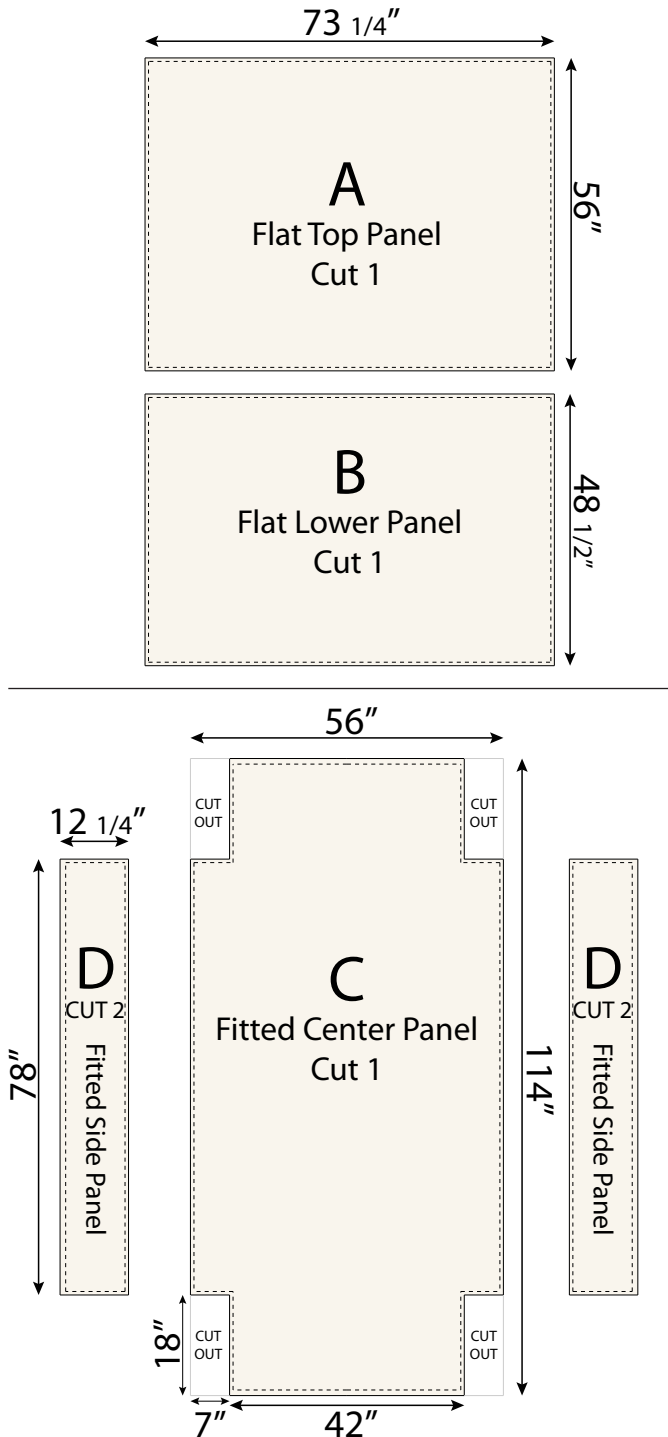

CUTTING LAYOUT

Trim selvage edges of fabric before cutting.

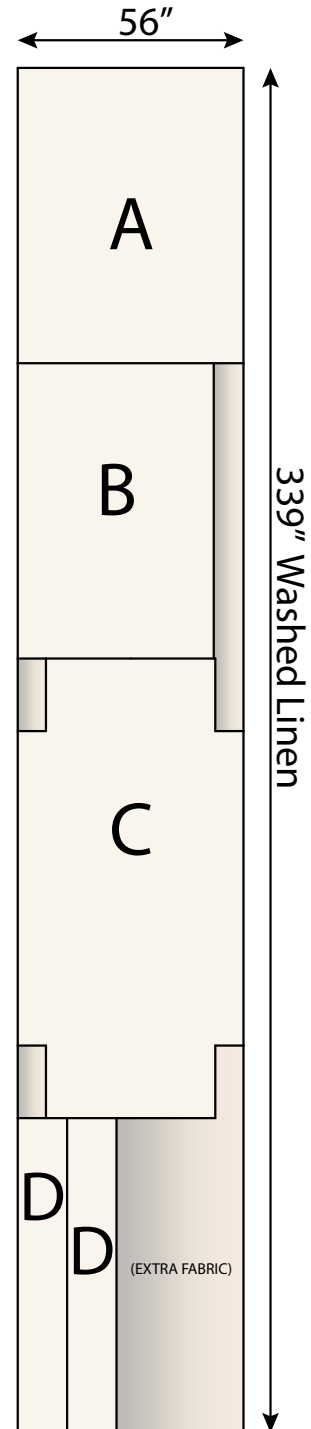

FULL FITTED & FLAT SHEET

PATTERN DIMENSIONS

Pattern includes all seam allowances. The indicated dimensions are for the CUT lines.

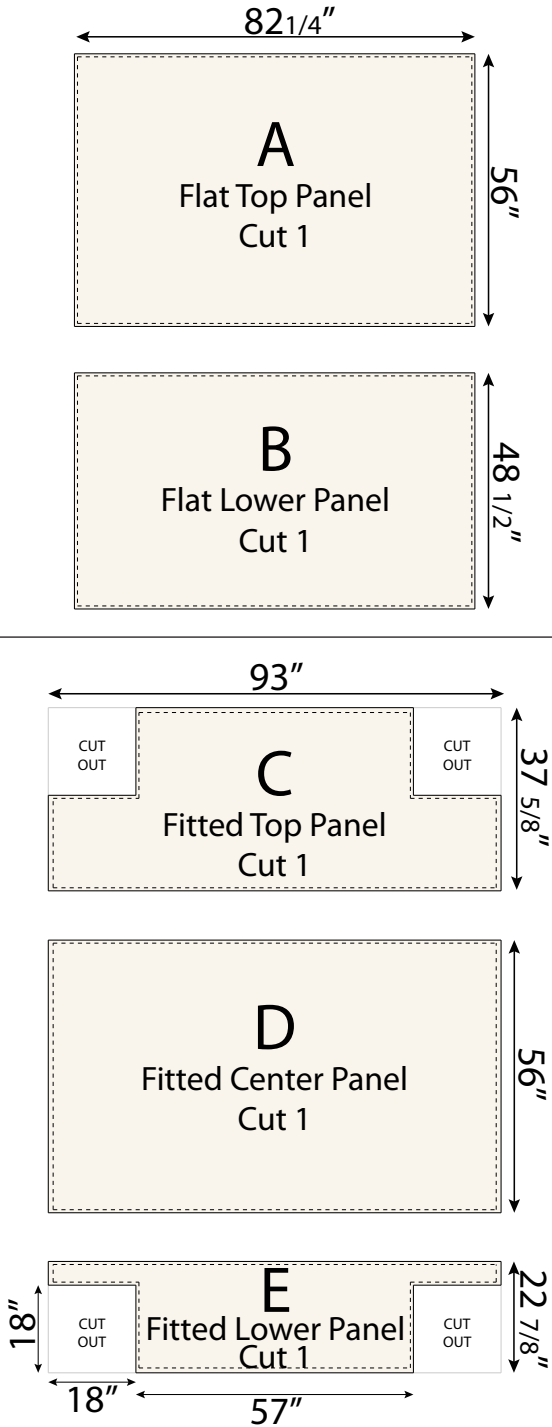

CUTTING LAYOUT

Trim selvage edges of fabric before cutting.

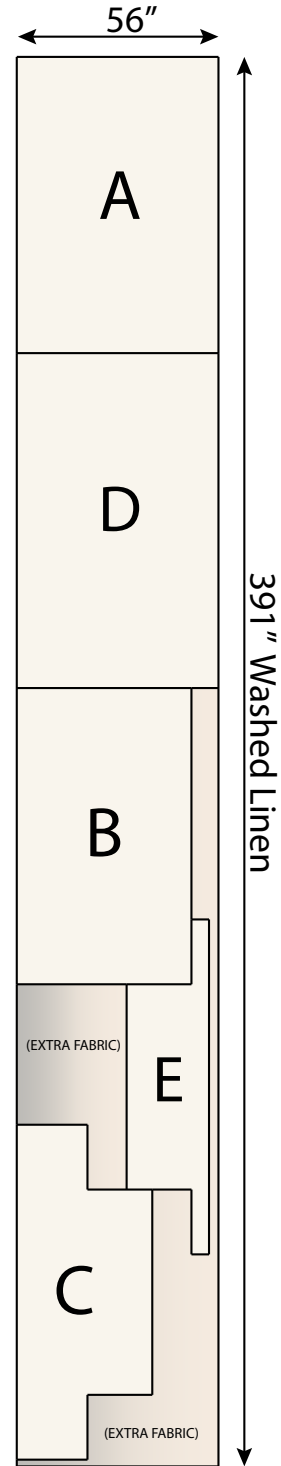

QUEEN FITTED & FLAT SHEET

PATTERN DIMENSIONS

Pattern includes all seam allowances. The indicated dimensions are for the CUT lines.

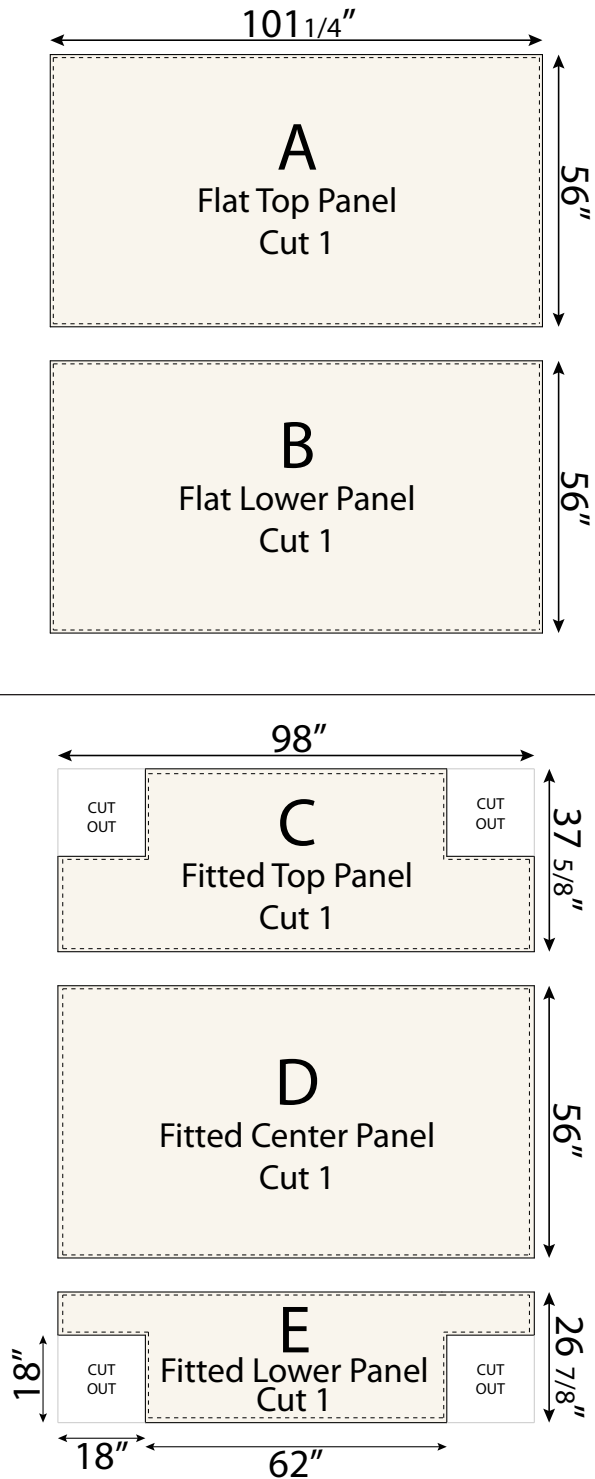

CUTTING LAYOUT

Trim selvage edges of fabric before cutting.

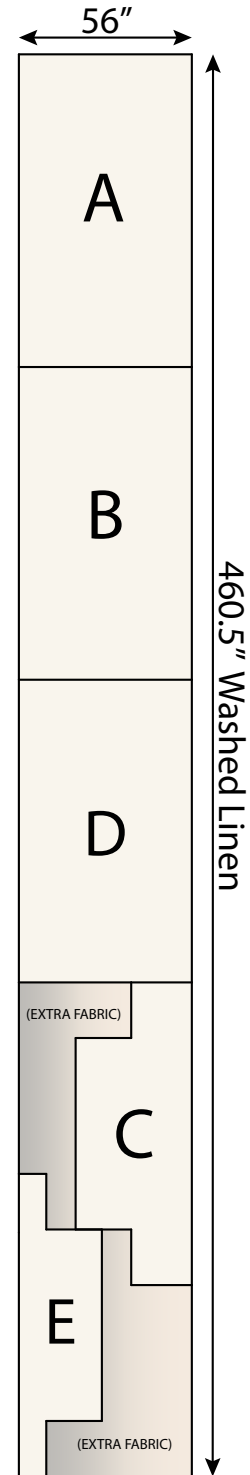

KING FITTED & FLAT SHEET

PATTERN DIMENSIONS

Pattern includes all seam allowances. The indicated dimensions are for the CUT lines.

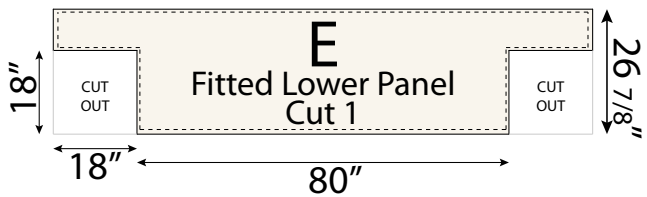
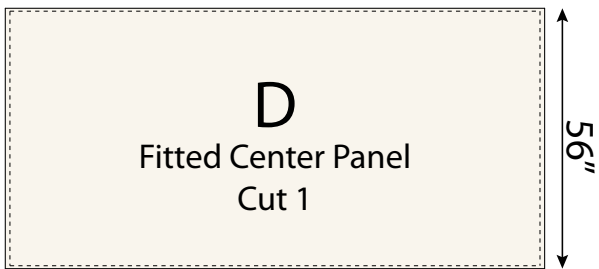
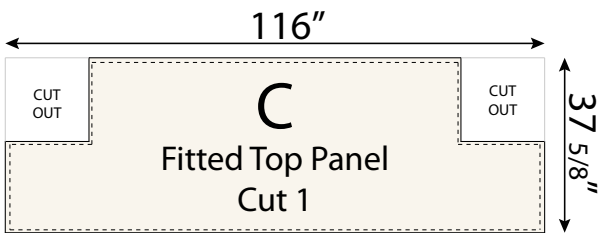
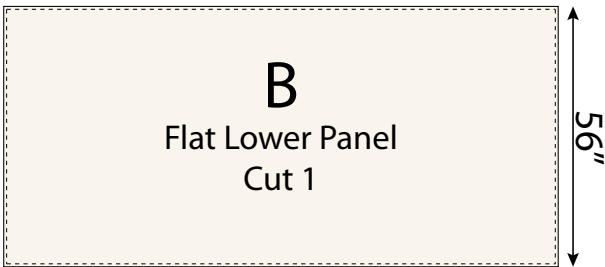
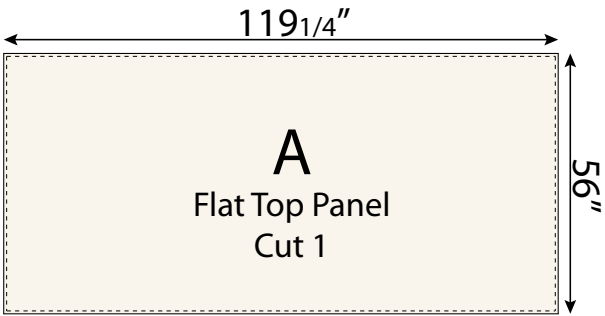

CUTTING LAYOUT

Trim selvage edges of fabric before cutting.

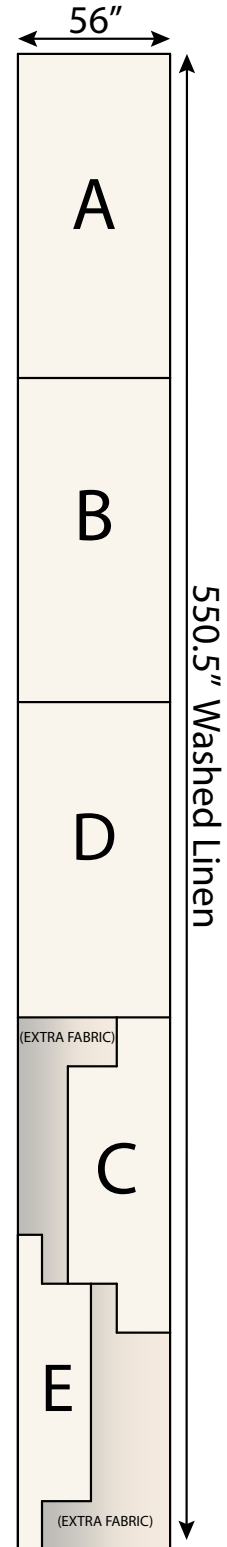

CALIFORNIA KING FITTED & FLAT SHEET

PATTERN DIMENSIONS

Pattern includes all seam allowances. The indicated dimensions are for the CUT lines.

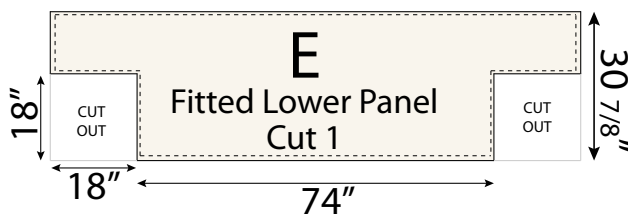
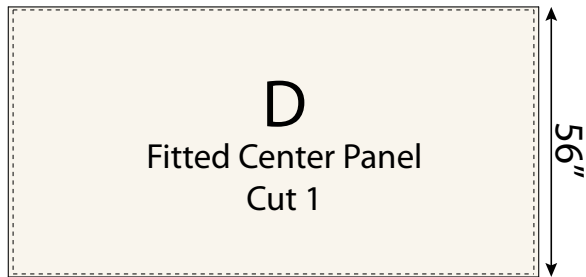
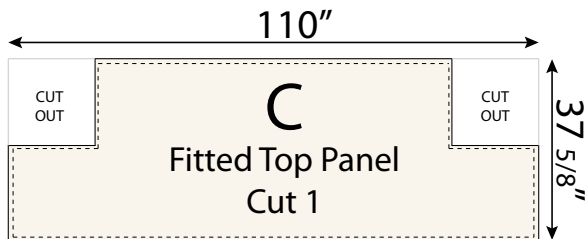
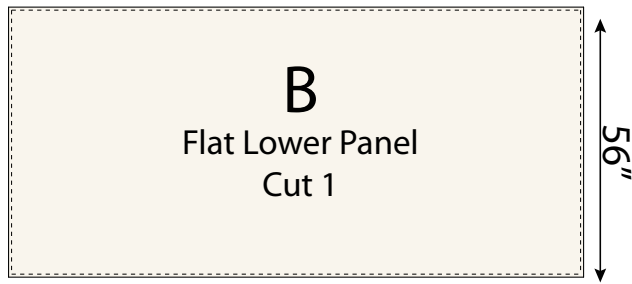
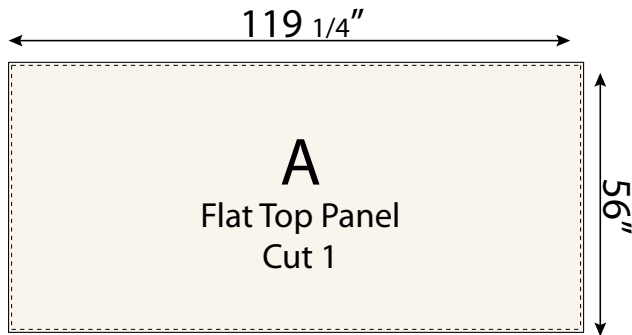

CUTTING LAYOUT

Trim selvage edges of fabric before cutting.

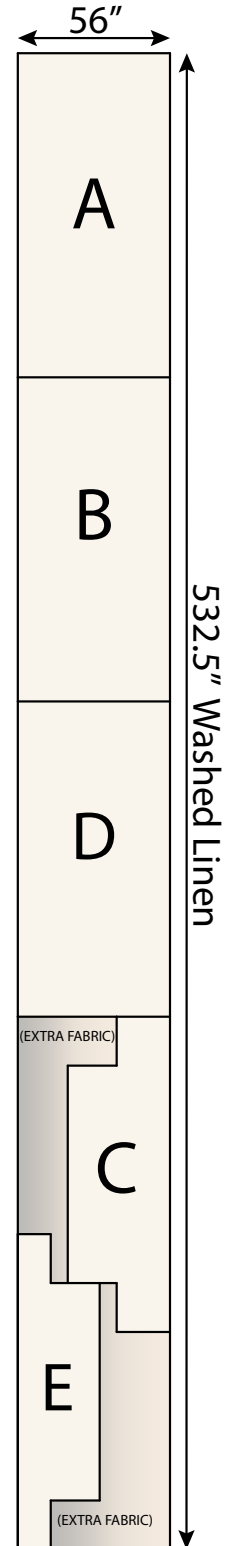

SEWING & PREPARATION TIPS:

Sewing with quality linen from Fabrics-Store is very enjoyable! Linen is a stable fabric that does not easily shift or slip, which is a very helpful characteristic for sewing a neat and even seam with little effort. You do not need to “push” or “pull” the fabric while sewing... just simply guide it.

Fine Seaming: To ensure that your seaming will last as long as your linen bed sheets, we encourage “single-needle” clean finished seaming with our step-by-step instructions. Setting the stitch length on your sewing machine to 2mm (about 12-14 stitches per inch) makes for a very durable seam, and is also an attractive indication of fine tailoring.

Instructions are written for the panel seams to be joined with open flat-felled seaming. The corner seams on the fitted sheet are sewn with French seams. While it is common to do all the seams with the French seam method, this can be quite bulky to sleep on. You will find that it is desirable for the panel seams to have as little bulk as possible. The French seam will have a total of 5 layers, whereas the open flat-felled seam will only have a total of 3 layers and no “lip” edges. If you are unsure which you would prefer or would like to practice, it is recommended you sew a sample swatch of each of these two methods to compare.

Alternate Seaming: If you instead prefer to stitch your seams regularly and serge the raw edges, simply sew the seams with the full 5/8” allowance. You can then serge the raw edges, allowing the machine to trim 1/8” off the edges. This will result in seam allowances finishing at 1/2”.

Pressing: For best results, it is highly recommended that you press your seams as you finish sewing each of them. Pressing with a steam iron (and press cloth if needed) will help “set” the stitches into the fabric. You will find it is much easier to press your seams “as you go” instead of trying to press them all after the sheets are finished.

Sewing Glossary: If certain sewing terms and techniques are new to you, please refer to the sewing glossary at the end of this document.

FABRIC REFERENCE KEY



RIGHT SIDE OF FABRIC



WRONG SIDE OF FABRIC

SEWING INSTRUCTIONS

In the following pages, you will find simple step-by-step instructions and illustrations on how to assemble and sew your beautiful linen sheets from start to finish in our fine linen.

Let's first start with a spare scrap of fabric to practice the two different seaming methods used in this tutorial. The open flat-felled seam is recommended for joining the panels, and the French seam is recommended for the corners of the fitted sheet.

OPEN FLAT-FELLED SEAM (PRACTICE)

Step 1: Press back each edge 1/4" towards wrong side of fabric.

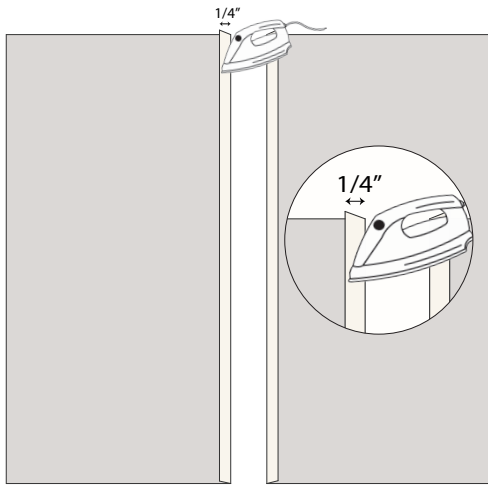

Step 2: With right sides together and folded outer edges aligned, stitch a 3/8" seam.

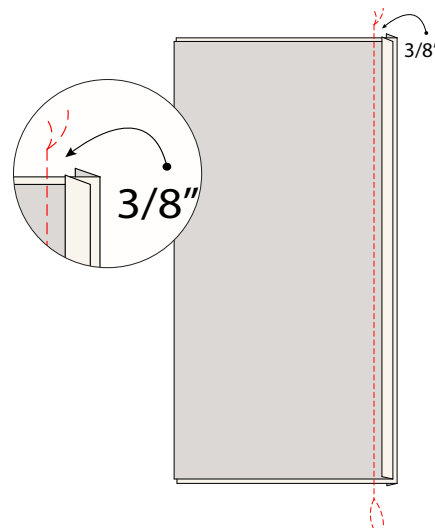

Step 3: Press open the seam allowance, with the first 1/4" still folded under.

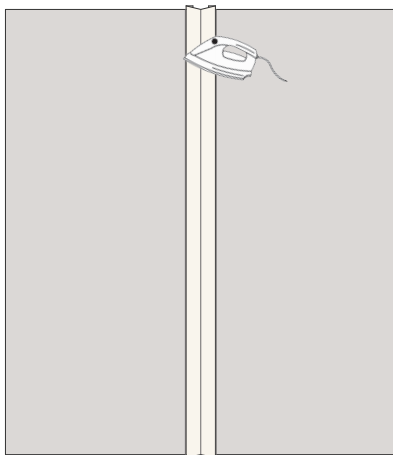

Step 4: Edge stitch 1/16" on each side of the folded seam allowance.

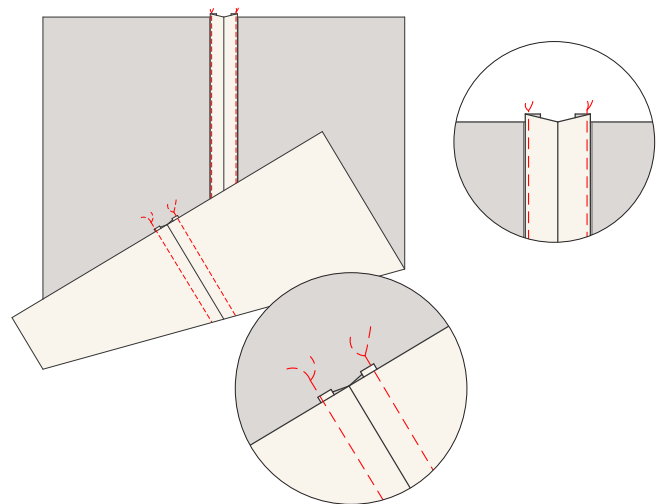

OPEN FLAT-FELLED SEAM: PHOTO DETAIL

Inside View:



Outside View:



FRENCH SEAM (PRACTICE)

Step 1: With WRONG sides together, align the two edges to be seamed with 1/4" stitch.

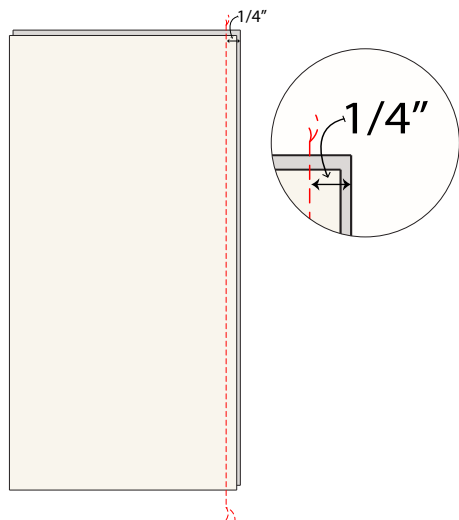

Step 2: Press seam allowance neatly to one side. Turn over and press out any lip edges.

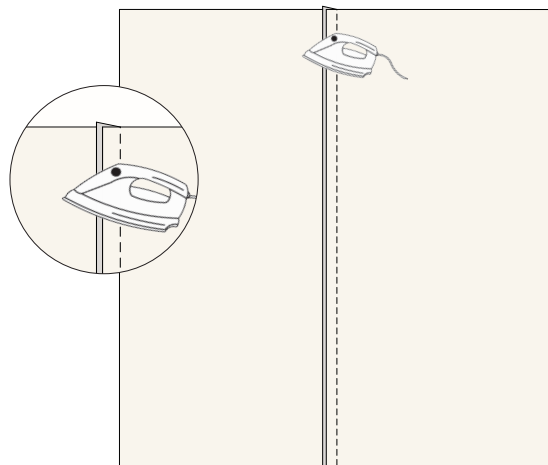

Step 3: Fold the fabric at the stitch line and press neatly.

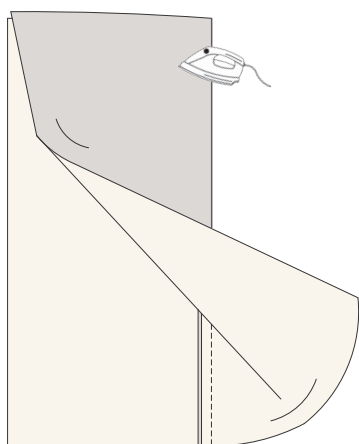

Step 4: Sew the second seam at 3/8", encasing the raw seam allowance inside.

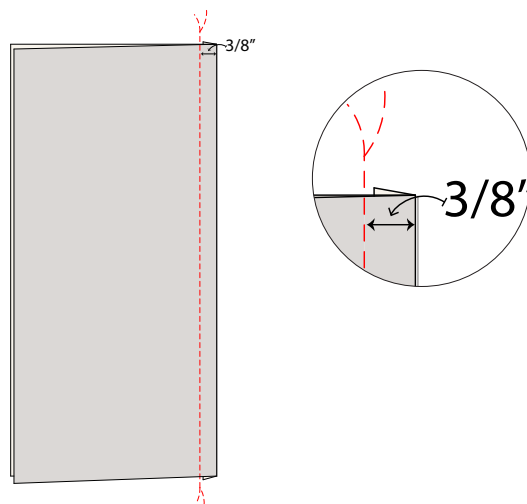

Now let's begin sewing your lovely linen sheets!

FRENCH SEAM: PHOTO DETAIL

Inside View:



Outside View:



1. JOIN THE PANELS

Sew the panel seams together for the fitted sheet and flat sheet using the recommended open flat-felled seaming, or if you prefer, the French seam. (Please note the Twin size fitted sheet will have vertical panels instead of horizontal panels.)

FLAT SHEET

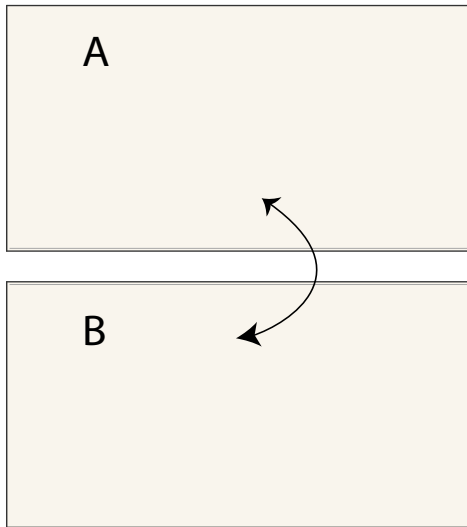

FITTED SHEET

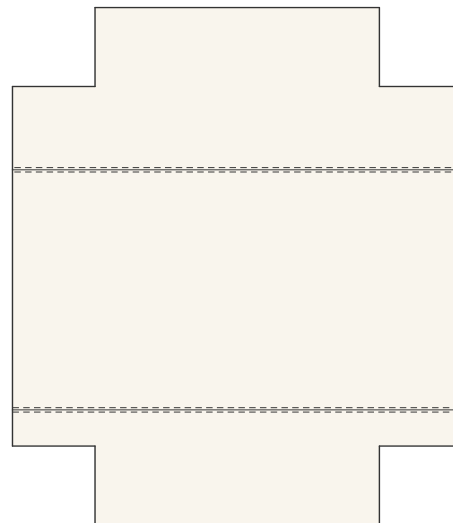
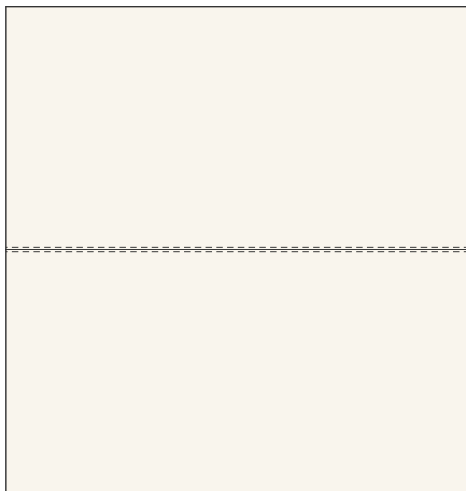
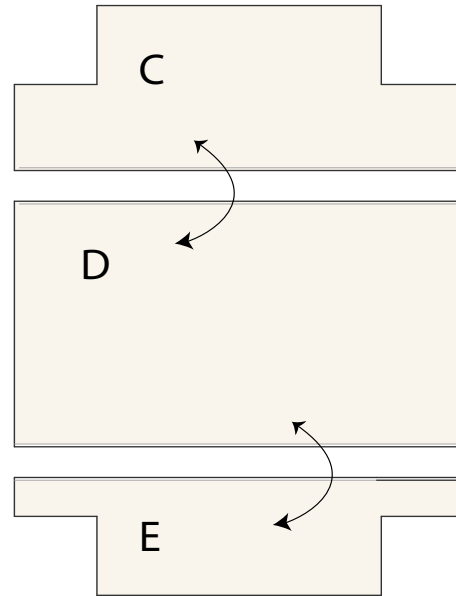

Keep in mind that washed and handled linen can shrink and ripple in some edges. This may cause you to feel like your panels do not “line up”. If this happens, start with your pins at each end and work your way to the center of each section, easing in any slight excess that one side might have. If you feel there was a cutting error, you could trim a little off the side that is too big.

2. FLAT SHEET: HEM EDGES

With wrong sides facing up, turn the raw edge up 1/4", then again 3/8" and top stitch.

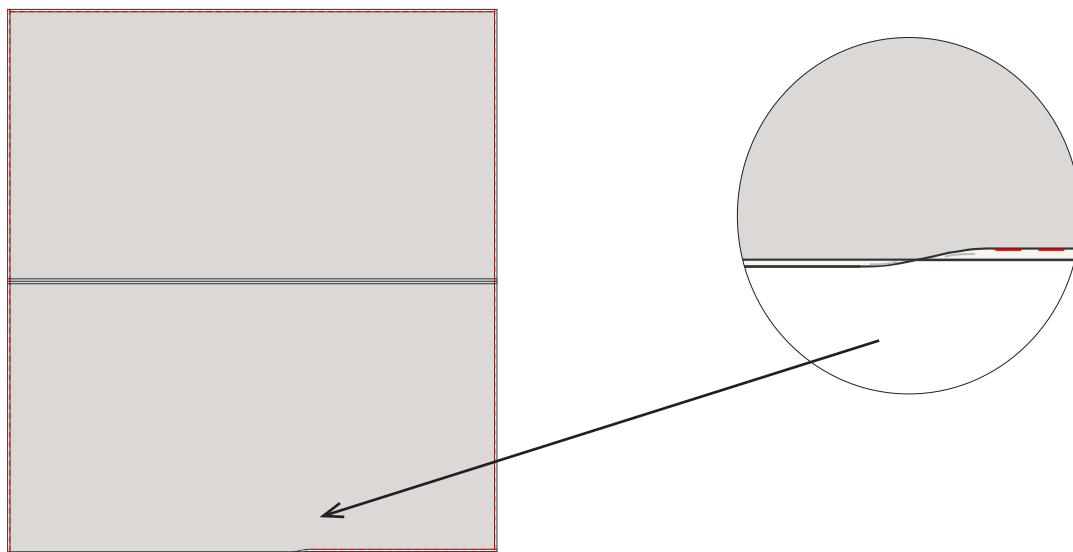

3. FITTED SHEET: ELASTIC SLIT FACINGS

Very likely, the elastic in your fitted sheets will wear out well before your linen does. For this reason, it is recommended that you have easy access to the elastic in the casings for replacing them when needed. Using scraps of fabric, cut 8 bias squares 1.5" x 1.5" and iron fusible interfacing to them for added durability. Create faced slits as shown in steps 1, 2, and 3. Each slot is placed about 14" from the cut edge of the corners.

8 bias-cut squares
1.5" x 1.5" with fusing

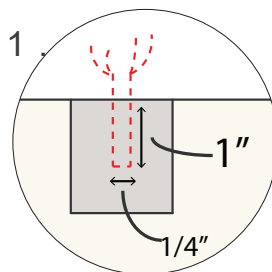
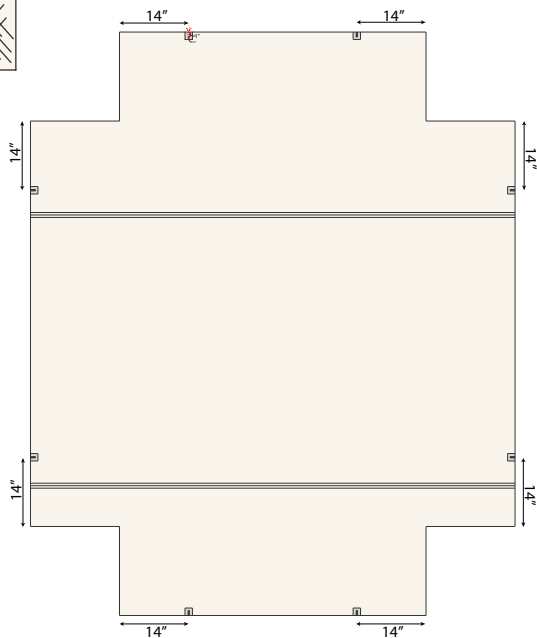

1. Right sides together, stitch 1" down from edge, pivot 1/4" and back up as shown.

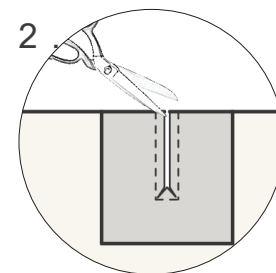

2. Trim slit and inner corners as shown.

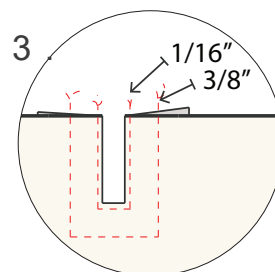

3. Turn facing to inside and topstitch edge of slit 1/16th and 3/8".

4. FITTED SHEET: SEAMING CORNERS

Next, sew the corners with French seams. Remember to sew the first seam with the wrong sides together at 1/4". Fold over and press, then do the second stitch line at 3/8".

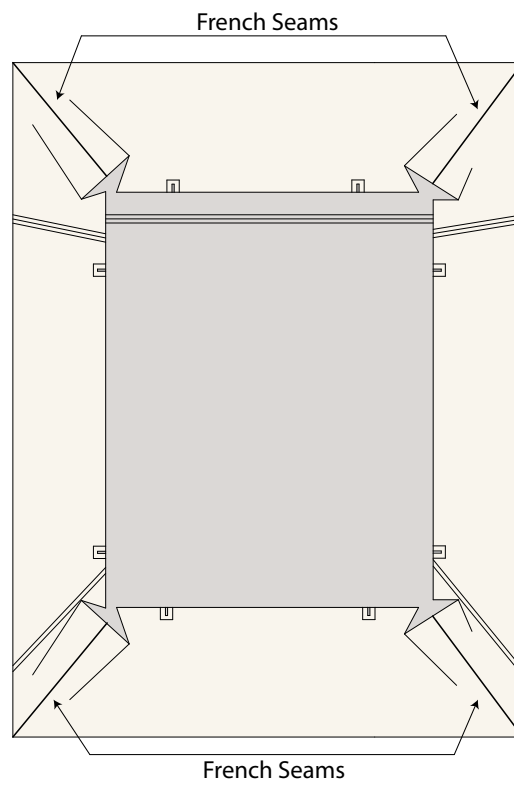

5. FITTED SHEET: HEM EDGES

Next, hem the edges by folding under 1/4", and again at 3/4" and top stitch.

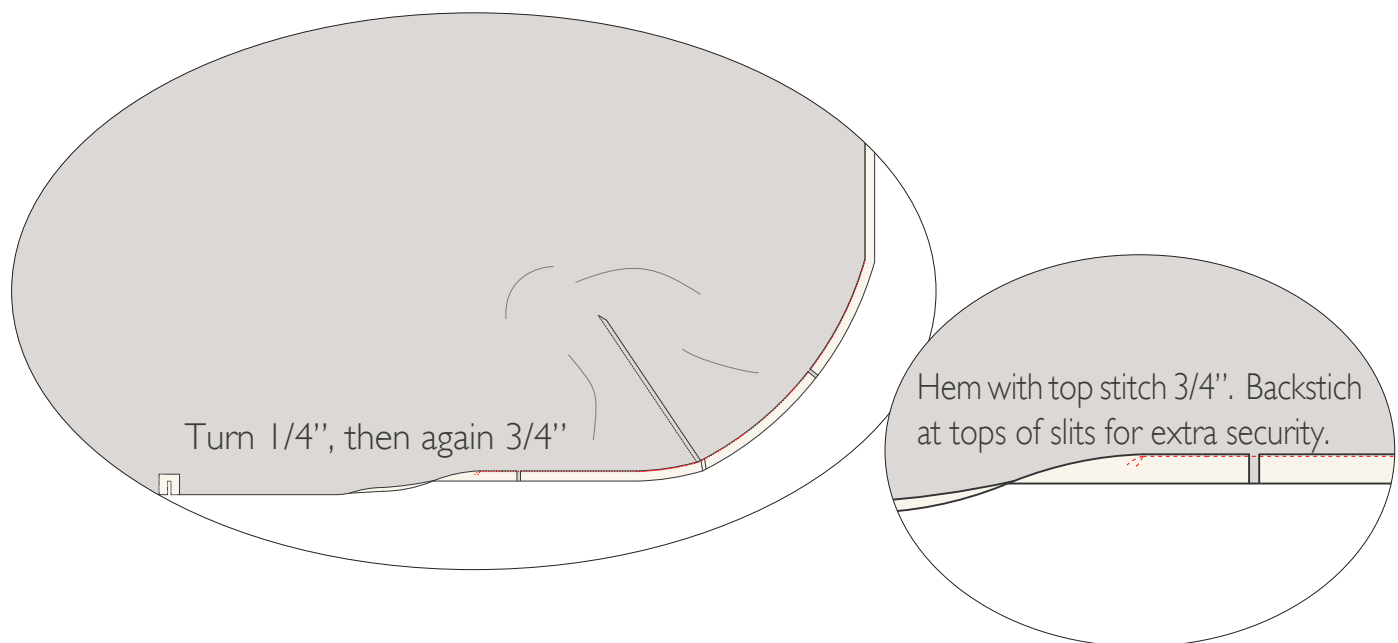

6. FITTED SHEET: INSERT ELASTIC

The last step is to insert the elastic into the casings. Using a safety pin, thread the elastic through one slit to the other side. Pull a few inches of elastic out of each end and secure with a safety pin. Try your fitted sheet on your mattress to see how tight your elastic needs to be adjusted. Once you have the right amount, secure each end of the elastic in place with a few rows of top stitching.

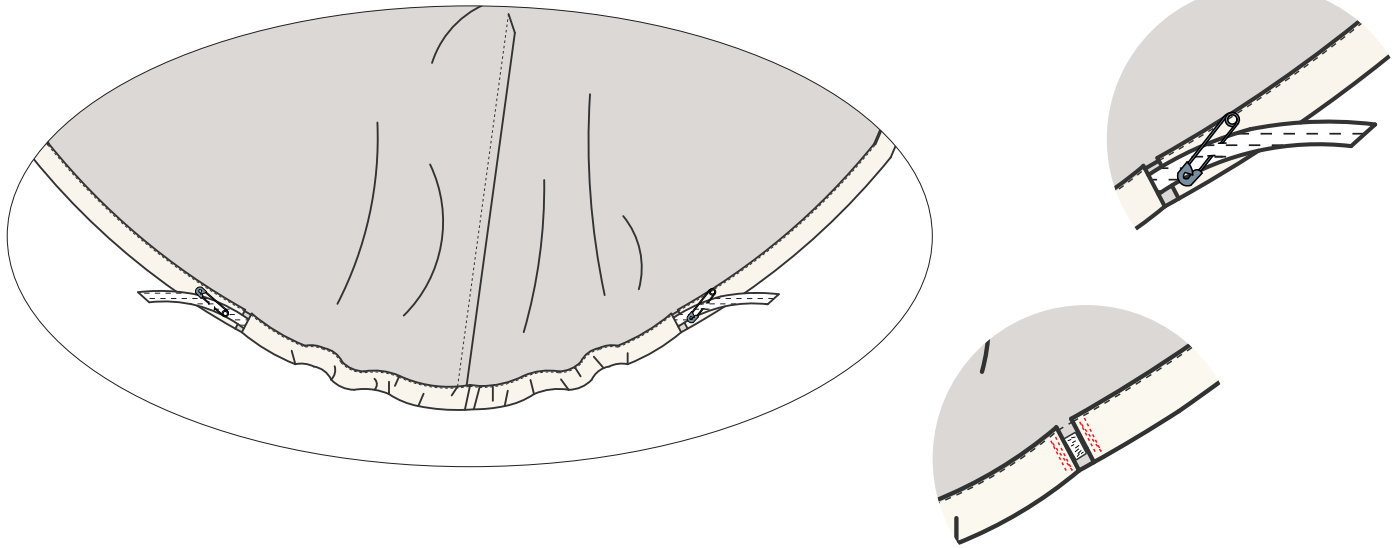

*Congratulations!
You have finished your linen bed sheets.*

Enjoy!

Bonus Embroidery Design

We have included a machine-embroidery small “Bee” design with this PDF as an attachment. Included are most of the popular embroidery machine formats. Alternatively, for hand-embroidery there is printable template/guide. Simply trace the design onto your fabric to embroider. This little bee is approximately 1.7 x 1.2 inches. Add a decorative border of these classic, whimsical bees for a designer touch. If desired, add an additional linen boarder to highlight the embroidery.

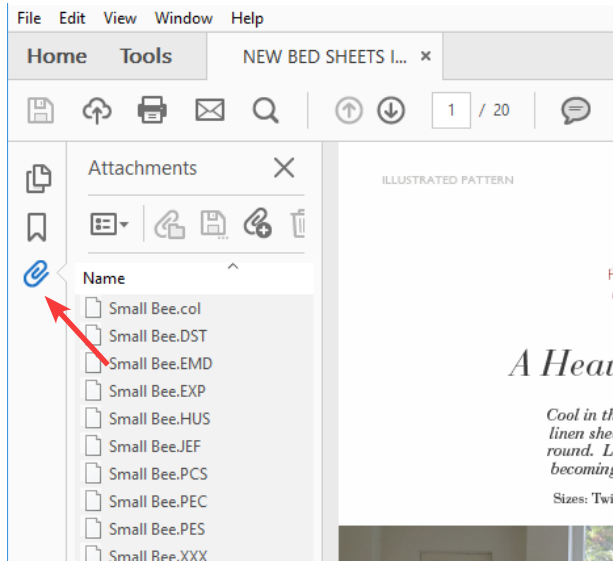

To access the file attachments, be sure you are viewing this PDF in the latest Adobe Acrobat Reader.

You can get/update the app for free here:

<https://get.adobe.com/reader/>

In Acrobat Reader, click on the “paper clip” icon to reveal the included files. Right-click on the desired embroidery file to download to your computer. Attached PDF files can simply be clicked to open and print.

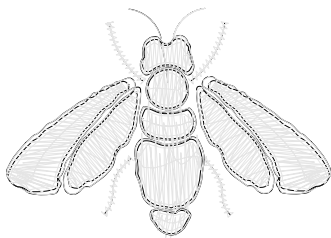

Glossary

Basting Stitch: A temporary hand or machine loose or long stitch to hold a seam in place before sewing the final permanent stitching.

Bias grain: In woven fabrics, this is the diagonal direction at 45 degrees to the grain and crossgrain. There are two bias directions in the cloth, perpendicular to each other.

Buttonhole: A slit in the fabric to fasten a button. The raw edges of the slit are finished with a machine or hand sewn zig-zag stitch.

Edge stitch: A row of top stitching very close to a seamed edge or folded edge, usually about 1/16th of an inch.

Fabric- right side: The side of the fabric which will be the exposed, outside part of a garment.

Fabric- wrong side: The inside of the fabric which will be the unexposed side or inside of a garment.

French seam: A seam sewn in two steps to encase the raw edges of the fabric within itself, giving a clean finish. 1- Wrong sides together, sew 1/4" seam. 2- Turn right sides together, stitch 3/8" seam. Total 5/8" seam allowance

Grainline- cross grain: The direction of fabric going from selvage edge to selvage edge. In woven fabric, these would also be known as the weft threads of the weave.

Grainline- on grain: The direction of fabric running parallel to the selvage edge of the cloth. This is also referred to as the "lengthwise grain". In woven fabric, these would also be known as the "warp" threads of the weave.

Notch- outward: Markings on the pattern that indicate an outward triangular cut outside the seam allowance. Notch markings will be arranged to show where two seam edges join properly together. A single wedge will often indicate a front piece, and 2 to 3 wedges together can indicate back pieces.

Notch- snip: Markings on the pattern that indicate a small "snip" into the seam allowance. Notch marking will be arranged to show where two seam edges join properly together. A single notch will often indicate a front piece, and 2 to 3 notches together can indicate back pieces.

Overlock machine: A specialized sewing machine designed to sew and cut along the raw edge of a fabric seam with a networked stitch to secure the edges from fraying. Also known as a "serger" machine.

Press cloth: A piece of cloth used to lay over a garment to protect it while ironing from burning or scorching. Usually made of cotton or linen or wool.

Raw edge: The cut edge of fabric. If not secured with stitching or a finishing, the raw edge of a fabric can fray or unravel.

Seam allowance: The distance from the cut edge of a pattern piece to the sewing line. Seam allowances can vary, so be sure to double check the indicated amounts on your pattern.

Thank you

*We work hard on making our patterns beautiful enough
to meet your standards.*

*If you feel like sharing praise or helpful criticism, please
send us your comments to ask@fabrics-store.com.*